

The CIO-MB and CIO-120-MB Modules are convenient and cost-effective Modbus-RTU (remote terminal unit) interfaces capable of providing discrete control and monitoring of a 777-P/P1 over a Modbus network. These devices can also be used as standalone devices in MCC (motor control center) or enclosed starter applications. The CIO-MB and CIO-120-MB are designed to provide the following benefits in both new and existing installations:

- reduced field wiring
- greater operator efficiency
- ease in system startup and commissioning

The CIO-MB/CIO-120-MB Modbus I/O Module provides four (4) inputs and two (2) AC/DC rated relay outputs. It can be DIN rail mounted or mounted directly to a back panel. The CIO-MB's/CIO-120-MB's compact size, ease of wiring and Modbus communications capability makes the use of traditional discrete devices on Modbus cost effective and simple. The CIO-MB/CIO-120-MB Module is compatible with SymCom's Model 777-P and 777-P1 overload relays. It simply connects to the side of the 777-P/P1 and, in addition to the extended I/O functions, permits remote monitoring and control of the 777-P/P1 over a Modbus network. An additional remote reset input is available on the CIO-MB/CIO-120-MB to reset a connected 777-P/P1.

The CIO-MB also possesses a Modbus message assembly feature. The user can configure a block of registers for periodic block reads which minimizes the memory requirements in the scanning device, PLC or SCADA system. It also simplifies the software because all of the data brought back in the device poll is used.

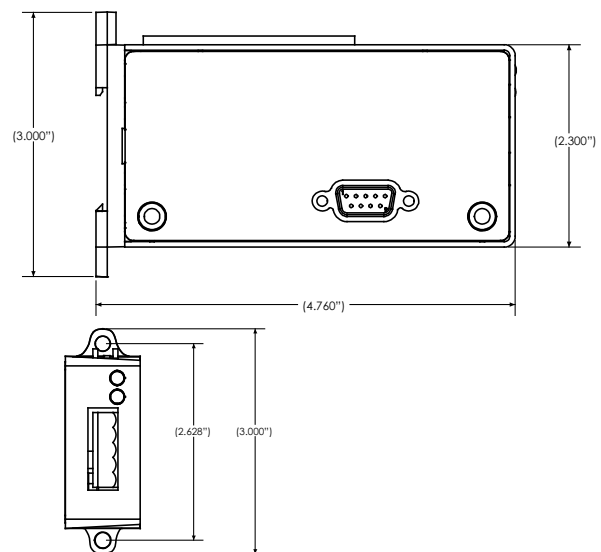
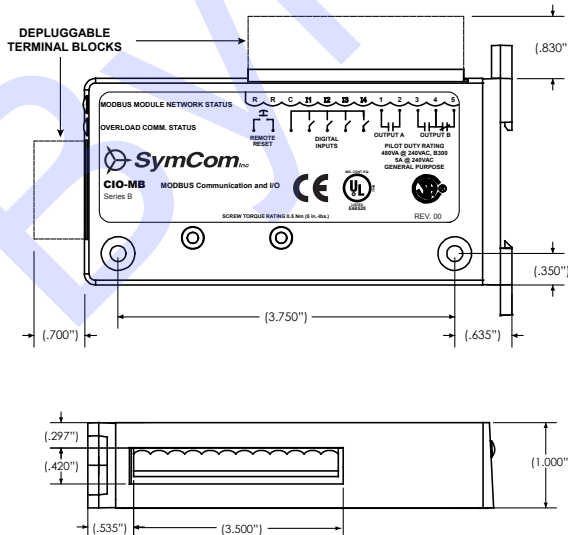

Specifications

Functional Specifications	
Remote Reset (for use with optional 777-P/P1 overload) Power Requirements Voltage Current Power	Normally open pushbutton rated 24VDC, 10mA (min.) 24VDC (+/- 10%) 95mA (max.) 70mA (typical) 2.28 Watts (max.) 1.7 Watts (typical)
Input Characteristics	
Voltage Range CIO-MB CIO-120-MB Current	12-24VDC 90-130VAC, 50/60Hz 2mA (typical)
Output Characteristics	
SPDT (1), SPST (1) Pilot Duty General Purpose	480VA @ 240VAC, B300 5A @ 240VAC
General Characteristics	
Operating Temperature Ambient Operating Ambient Storage Terminal Torque Wire AWG Class of Protection Relative Humidity Standards Passed Electrostatic Discharge (ESD) Radio Frequency Immunity, Radiated Fast Transient Burst Hi-Potential Test Surge Input Power Inputs/Data Lines Safety Marks UL CSA CE Enclosure Dimensions Weight Mounting Method	-20° to 70°C (-4° to 158°F) -40° to 80°C (-40° to 176°F) 3in.-lbs. (max.) 12-20 AWG IP20, NEMA 1 (finger safe) 10-95%, non-condensing per IEC 68-2-3 IEC 1000-4-2, Level 3, 6kV contact, 8kV air 150 MHz, 10V/m IEC 1000-4-4, Level 3, 4kV input power Meets UL508 (2 x rated V + 1000V for 1 minute) IEC 1000-4-5, Level 1 IEC 1000-4-5, Level 2 UL508 C 22.2 IEC Polycarbonate 4.76"L x 3.00"W x 1.0"D 14 oz. #8 screws or DIN rail mountable

How to order:

Part Number: CIO-MB
CIO-120-MB

