

INSTALLATION INSTRUCTIONS FOR MODEL CIO-DN-P, COM-DN-P, CIO-120-DN-P, CIO-601CS-DN-P1 DeviceNet I/O MODULES

DANGER!



HAZARDOUS VOLTAGES MAY BE PRESENT DURING INSTALLATION.

Electrical shock can cause death or serious injury.

Installation should be done by qualified personnel following all national, state and local electrical codes.



**BE SURE POWER IS DISCONNECTED PRIOR TO INSTALLATION!
FOLLOW NATIONAL, STATE AND LOCAL CODES.
READ THESE INSTRUCTIONS ENTIRELY BEFORE INSTALLATION.**

The CIO-xxx-DN-Px, CIO-601CS-DN-P1 or COM-DN-P Modules are convenient and cost-effective DeviceNet interfaces capable of providing discrete control and monitoring of motor starters, drives, and other devices over a DeviceNet network. The CIO-xxx-DN-Px, CIO-601CS-DN-P1, COM-DN-P are designed to provide the following benefits in both new and existing installations:

- § reduced field wiring
- § greater operator efficiency
- § ease in system startup and commissioning

The CIO-xxx-DN-Px, CIO-601CS-DN-P1 DeviceNet I/O Module provides four (4) inputs and two (2) AC/DC rated relay outputs. It can be DIN rail mounted, or mounted directly to a back panel. The CIO-xxx-DN-Px, CIO-601CS-DN-P1, COM-DN-P compact size, ease of wiring and DeviceNet communications capability makes the use of traditional discrete devices on DeviceNet cost-effective and simple. The CIO-xxx-DN-Px or COM-DN-P Module is compatible with SymCom's Model 777-P (P1) overload relay. It simply connects to the side of the 777-P and, in addition to the extended I/O functions (CIO-xxx-DN-Px), permits remote monitoring and control of the 777-P (P1) over a DeviceNet network. An additional remote reset input is available on the CIO-xxx-DN-Px or COM-DN-P to reset a connected 777-P (P1). The CIO-601CS-DN-P1 is compatible only with the 601-CS power monitor.

CONNECTIONS

1. Mount the CIO-xxx-DN-Px, CIO-601CS-DN-P1, COM-DN-P in a convenient location in a properly rated enclosure. CIO-xxx-DN-Px, CIO-601CS-DN-P1 can be mounted to a back panel using screws or can be snapped onto DIN rail.
2. Connect the five DeviceNet wires to the 5-pin connector on the front of the CIO-xxx-DN-Px, COM-DN-P, and CIO-601CS-DN-P1 module. 24VDC should be connected to V+ and V-. Connect the other three wires to CAN High, CAN Low and Shield.

3. CIO-DN-Px, CIO-601CS-DN-P1 and CIO-120-DN-Px Connections

NOTE: CIO-DN-Px, CIO-601CS-DN-P1 inputs are dry contact inputs only, and CIO-120-DN inputs require AC voltage.

CIO-DN-Px, CIO-601CS-DN-P1 inputs

Connect one side of each input contact to C and connect the other side to I1, I2, I3, or I4.

CIO-120-DN-Px inputs

Connect L1 of an AC source to C (AC common) connect L2 of an AC source to each input contact, Connect the other side of each input contact to I1, I2, I3, or I4. The CIO-120-DN-Px must see AC voltage to indicate the input is closed.

4. The MNS LED indicates communication is established between the CIO-xxx-DN-Px, CIO-601CS-DN-P1 and the DeviceNet master, and OLC indicates communication is established with the 777-P (P1) overload or 601-CS (if installed).
5. OUTPUT A, OUTPUT B and the REMOTE RESET connections are made to the top green connector of the CIO-xxx-DN-Px, CIO-601CS-DN-P1 Module.

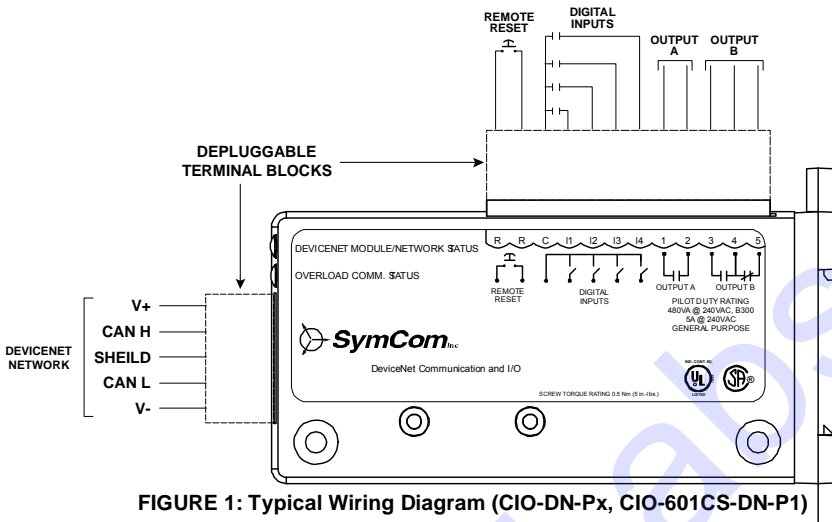

FIGURE 1: Typical Wiring Diagram (CIO-DN-Px, CIO-601CS-DN-P1)

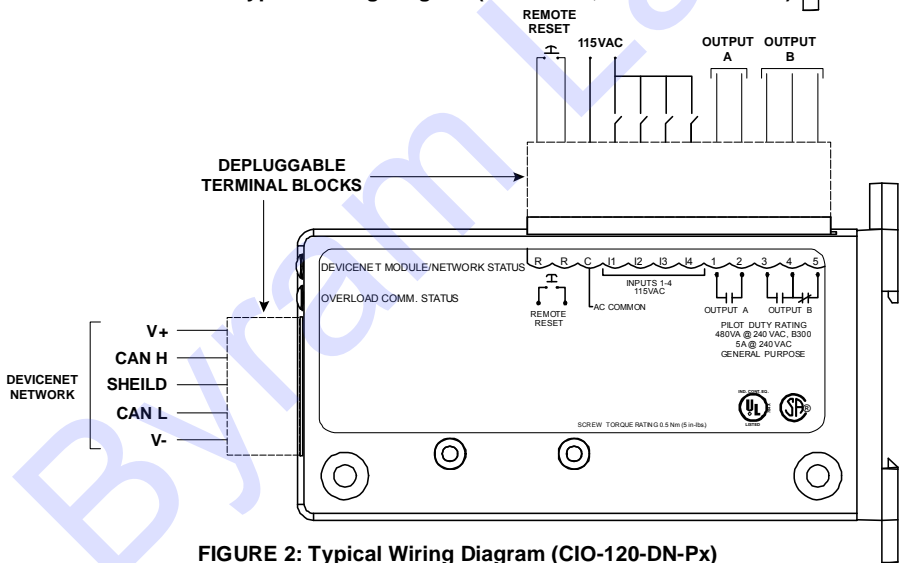

FIGURE 2: Typical Wiring Diagram (CIO-120-DN-Px)

TABLE 1: CIO-DN-Px, CIO-120-DN-P, CIO-601CS-DN-P1 Terminals

| Terminal Designations | Function |
|-----------------------|--------------------------|
| V+ | DeviceNet Power |
| CAN H | Signal High |
| SHEILD | Shield Tie Point |
| CAN L | Signal Low |
| V- | DeviceNet Common |
| R | Remote Reset Switch |
| R | Remote Reset Switch |
| C | Input Common |
| I1 | Input 1 |
| I2 | Input 2 |
| I3 | Input 3 |
| I4 | Input 4 |
| 1 | Output A terminal 1 |
| 2 | Output A terminal 2 |
| 3 | Output B normally open |
| 4 | Output B common |
| 5 | Output B normally closed |

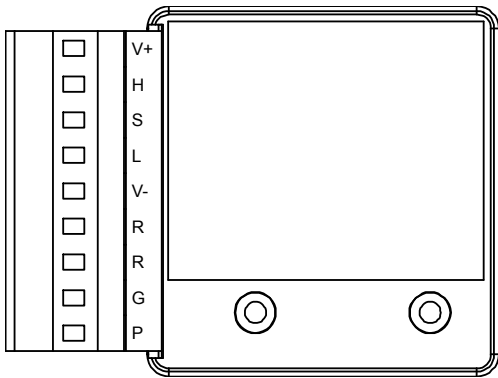

FIGURE 3: COM-DN Typical Wiring Diagram

TABLE 2: COM-DN-P Terminals

| Terminal Designations | Description |
|-----------------------|---------------------|
| V+ | DeviceNet Power |
| H | Signal High |
| S | Shield Tie Point |
| L | Signal Low |
| V- | DeviceNet Common |
| R | Remote Reset Switch |
| R | Remote Reset Switch |
| G | Do not use |
| P | Do not use |

DIAGNOSTIC INDICATOR LIGHTS (CIO-XXX-DN-Px, CIO-601CS-DN-P1 only)

The unit is energized when power is applied between V+ and V- on the connector. The MNS and OLC lights will flash until communication is established. The MNS LED indicates the state of the DeviceNet connection to the module. The OLC LED indicates the state of the Modbus connection to the module. For a complete description of the indicator LEDs see tables 3 and 4 below:

| Table 3: MNS LED State Table | | |
|--|----------------------|--|
| For this state: | LED is: | To indicate: |
| Not Powered/Not On-line | Off | Device is not on-line. - The device has not completed the Dup_MAC_ID test yet. - The device may not be powered. |
| Device Operational AND On-line, Connected | Green | The device is operating in a normal condition and the device is on-line with connections in the established state. - For a Group 2 Only device it means that the device is allocated to a Master. - For a UCMM capable device it means that the device has one or more established connections. |
| Device Operational AND On-line, Not Connected or Device On-line AND Device needs commissioning | Flashing Green | The device is operating in a normal condition and the device is on-line with no connections in the established state. - The device has passed the Dup_MAC_ID test, is on-line, but has no established connections to other nodes. - For a Group 2 Only device it means that this device is not allocated to a master. - For a UCMM capable device it means that the device has no established connections. - Configuration missing, incomplete or incorrect. |
| Minor Fault and/or Connection Time-Out and/or No Network Power | Flashing Red | Any one or more of the following conditions: - Recoverable fault - One or more I/O Connections are in the Timed-Out state - No network power present |
| Critical Fault or Critical Link Failure | Red | The device has an unrecoverable fault; may need replacing. Failed communication device. The device has detected an error that has rendered it incapable of communicating on the network (Duplicate MAC ID, or Bus-off). |
| Communication Faulted and Received an Identify Comm Fault Request - Long Protocol | Flashing Red & Green | A specific Communication Faulted device. The device has detected a Network Access error and is in the Communication Faulted state. The device has subsequently received and accepted an Identify Communication Faulted Request - Long Protocol message. |

| Table 4: OLC LED State Table | | |
|-------------------------------------|----------------|---|
| For this state | LED is: | To Indicate: |
| Modbus Comm. Established | Solid Green | Communication established with attached Modbus device |
| Modbus Comm. Failed | Flashing Green | Communication lost with attached Modbus device |

REMOTE RESET

The R terminals can be connected to a normally open pushbutton to remotely reset a connected 777-P (P1) overload.

DEVICENET NETWORK CONFIGURATION

Cable Routing

Follow these general cable-routing guidelines:

- Avoid areas of high temperature, moisture, vibration, or other mechanical stress.
- Secure the cable where necessary to prevent damage.
- Use cable ducts, raceways, or other structures to protect the cable.
- Never route cables over or around sharp edges.
- Avoid sources of electrical interference that can induce noise into the cable. Use the maximum practicable separation from such sources. Run communication cables at right angles to power cables.
- Maintain a minimum separation of 3.3 ft. (1m) from the following equipment:
 - air conditioners and large blowers
 - elevators and escalators
 - radios and televisions
 - intercom and security systems
 - fluorescent, incandescent, and neon lighting fixtures
- Maintain a minimum separation of 10 ft. (3m) from the following equipment:
 - Line and motor power wiring
 - Transformers
 - Generators
 - Alternators

Cable Length and Wiring

The maximum permissible length of the bus cable depends on the communication baud rate and the cable used. See the following equation and table below for mixed cable use.

In addition, the configuration of the wiring system must comply with the rules for trunk and drop cable configuration and length. The following are basic wiring rules:

- 120Ω terminating resistors are required on each end of the trunk line in accordance with ODVA standards.
- The trunk must be configured as a linear bus or daisy chain. Star and ring structures are not allowed.
- Drop lines may be as long as 20 ft. (6m) and may contain branches.

Calculate the maximum length of mixed cables using the following equation:

$$L_{\text{Thick}} + 5 * L_{\text{Thin}} = 1640 \text{ ft. (500m)}$$

$$L_{\text{Thin}} \text{ must not exceed } 512 \text{ ft. (156m)}$$

| Baud Rate | DeviceNet Cable | | Maximum Length | |
|------------------|------------------------|----------------|-----------------------|-----------------------|
| | Thick | Thin | Drop Line | All Drop Lines |
| 125 kbps | 1640 ft. (500m) | 328 ft. (100m) | 20 ft. (6m) | 512 ft. (156m) |
| 250 kbps | 820 ft. (250m) | 328 ft. (100m) | 20 ft. (6m) | 512 ft. (156m) |
| 500 kbps | 1640 ft. (500m) | 328 ft. (100m) | 20 ft. (6m) | 512 ft. (156m) |

Equipment Setup

1. Connect the DeviceNet trunk cable to the DeviceNet scanner interface being used.
2. Connect the CIO-xxx-DN-Px, CIO-601CS-DN-P1, COM-DN-P DeviceNet I/O Module to the network using the DeviceNet terminals on the front of the unit.

Check that the 24VDC power supply disconnect switch is ON and that 24VDC is present on the DeviceNet network cable (V+ and V- at any location).

SOFTWARE CONFIGURATION

Quick-Start Guide Using SymCom Solutions EDS and ICO Files

EDS (electronic data sheet) files are required for DeviceNet network and DeviceNet master software configuration. An EDS file contains information about configurable attributes for a device, including object addresses of each parameter.

The ICO file includes a custom icon to personalize the configuration software. The EDS and ICO files are available on SymCom's website at www.symcom.com > Products > Communications > COM-DN DeviceNet Communication Module > EDS File for COM-DN-P. Upload the EDS file to your system to access relevant files.

Network Setup

1. Open Solutions
2. Click DeviceNet USB/CAN to open a network view. Click Tools > **EDS Manager** to open the EDS manager dialog box. Click **Import** and open the EDS file you uploaded. The file will be imported—then **Close** the dialog boxes to get back to the network view.
3. Right click the network window and select **Auto Detect for Units**. All units on the network will be auto detected and should appear on the screen—click on a unit to view its properties.

DIMENSIONS (COM-DN-P)

All dimensions are in inches.

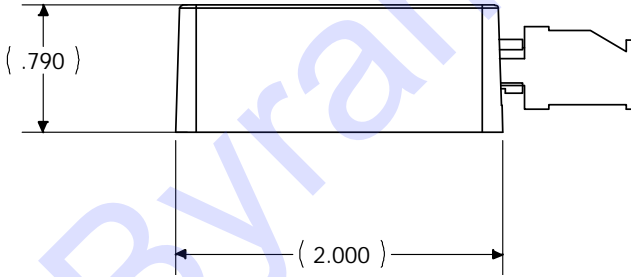
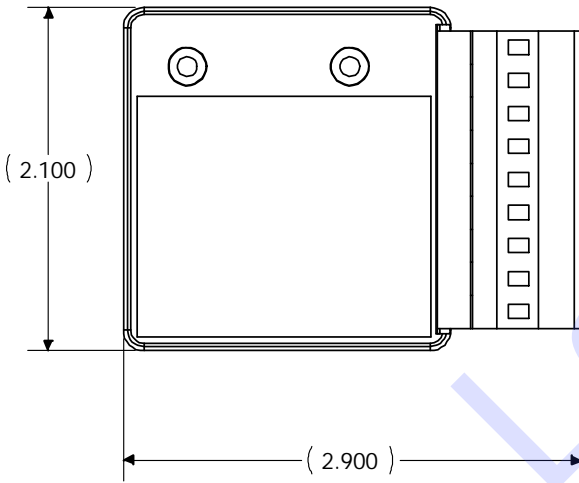

DIMENSIONS (CIO-DN-Px, CIO-120-DN-Px, CIO-601CS-DN-P1)

All dimensions are in inches.

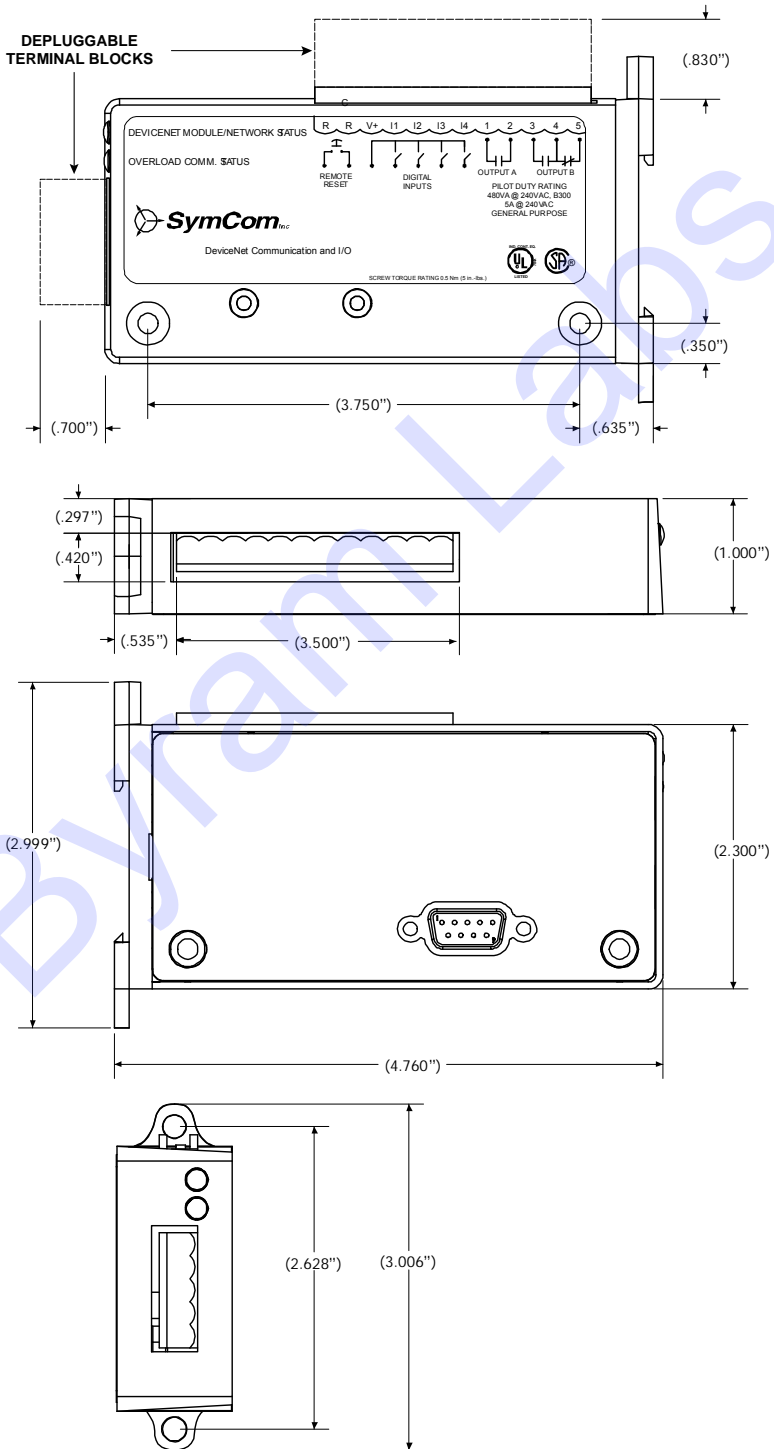

TABLE 6: CIO-DN-Px, CIO-120-DN-Px, CIO-601CS-DN-P1, COM-DN-P SPECIFICATIONS

| Output Relay Contact Rating – SPDT (1), SPST (1) (CIO-DN-Px or CIO-120-DN-Px, CIO-601CS-DN-P1) | |
|---|--|
| Pilot Duty | 480VA @ 240VAC, B300 |
| General Purpose | 5A @ 240VAC |
| Inputs (4) – general purpose (CIO-DN, CIO-120-DN, CIO-601CS-DN-P1 Only) | |
| Voltage Range | 12–24VDC (module powered, V+ CIO-DN-Px or CIO-601CS-DN-P1 only) 90–130VAC, 50/60Hz (CIO-120-DN-Px only) |
| Current | 2mA (typical) |
| Remote Reset (for use with optional 777-P overload) | Normally open pushbutton rated 24VDC, 10mA (min.) |
| Power Requirements | |
| Voltage | 12–24VDC |
| Current | 137mA (max.) CIO-DN-Px, CIO-120-DN-Px, CIO-601CS-DN-P1 40mA (continuous) COM-DN-Px |
| Power | (3.28 Watts (max. CIO-DN-Px, CIO-120-DN-Px, CIO-601CS-DN-P1) (1.7 Watts (max. COM-DN-P) |
| Weight | 14 oz. (CIO-DN-Px or CIO-120-DN-Px, CIO-601CS-DN-P1) 1.6 oz. (COM-DN-P) |
| Enclosure | Polycarbonate |
| Terminal (depluggable terminal block) | |
| Torque | 3 in.-lbs. (max.) |
| Wire AWG | 12–20 AWG |
| Safety Marks | |
| UL | UL508 (File #E68520) |
| CSA | C 22.2 |
| Standards Passed | |
| Electrostatic Discharge (ESD) | IEC 1000-4-2, Level 3, 6kV contact, 8kV air |
| Radio Frequency Immunity, Radiated | 159 MHz, 10V/m |
| Fast Transient Burst | IEC 1000-4-4, Level 3, 4 kV input power |
| Hi-Potential Test | Meets UL508 (2 x rated V + 1000V for 1 minute) |
| Environmental | |
| Temperature Range | Ambient Operating: -20° to 70°C (-4° to 158°F) Ambient Storage: -40° to 80°C (-40° to 176°F) |
| Class of Protection | IP20, NEMA 1 (Finger Safe) |
| Relative Humidity | 10-95%, non-condensing per IEC 68-2-3 |
| DeviceNet | |
| DeviceNet conformance self-tested | |