

ALPHA Plus® Meter



ALPHA Plus Means Powerful Metering

Elster Electricity's ALPHA Plus meter is a powerful meter that builds on the patented ALPHA® metering technology. The ALPHA Plus meter can be a single phase, 240 volt, one-rate demand meter or a polyphase, wide voltage supply, multi-rate, real/reactive meter that validates meter service connections automatically, performs power quality monitoring, and provides load profile reading with remote communications.

Load Profile and Event Logs

The main circuit board has 28 KB of memory available to record load profile and data logs. The following table shows an example of the quantity of load profile data the meter can store with a 15-minute demand interval.

Number of channels	Maximum days stored
1 channel	141 days*
4 channels	36 days*

*Number of days may be fewer depending on the number of event log entries.

The integrity of load profile data does not depend on the meter battery because load profile memory is stored in nonvolatile EEPROM. When enabled with the load profile capability, the ALPHA Plus meter records date and time stamps for the following events:

- power fail
- test mode
- time change
- demand reset

With power quality monitoring enabled, the meter also includes date and time stamps of PQM events, including voltage sags.

Power Quality Monitoring

When this feature is enabled, the ALPHA Plus meter searches for exceptions to user-defined thresholds for items such as voltage, current, power factor, and total harmonic distortion. The meter performs various tests that measure and collect power quality data 24 hours a day.

System Service Tests

System service tests are performed to check the validity of the electrical service as wired to the meter. The ALPHA Plus meter verifies the service type, phase rotation, and validity of phase voltages. The ALPHA Plus meter also determines if phase currents are within a user-defined threshold.

Instrumentation

Instrumentation values provide near instantaneous analysis of the electrical service. All quantities can be programmed to display on the LCD in the normal or alternate display sequence:

- per phase voltage and per phase current
- per phase voltage and per phase current phase angles (as measured to phase A voltage)
- per phase current phase angle as measured to same-phase voltage
- per phase power factor and power factor angle
- per phase kW, kVAR, and kVA
- per phase total harmonic distortion for both voltage and current
- system frequency
- system kW, kVAR, kVA, power factor, and power factor angle

Revenue Metering

A1K+ and A1R+ meters measure, store, and display a full set of energy and demand values for both real/apparent and real/reactive quantities, respectively. These meters provide two complete blocks of time-of-use data. Each TOU rate is supported by separate fractional energy registers.

The A1R+ meter offers vectorial kVA values as a metered quantity choice. Average PF can be displayed when kW and kVA are selected as metered quantities.

Discover the value of the diamond

ELSTER

Communications

Data can always be retrieved using the standard optical port. By adding an option board, additional communications interfaces are available for the ALPHA Plus meter, including the following:

- 2400 bps internal telephone modem with outage callback
- RS-232 serial interface
- RS-485 serial interface
- 20 mA current loop
- external serial interface

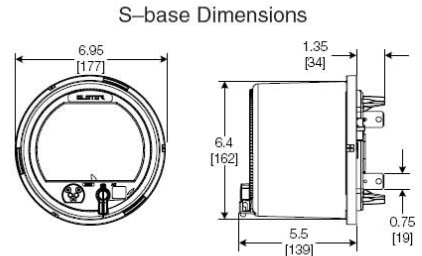
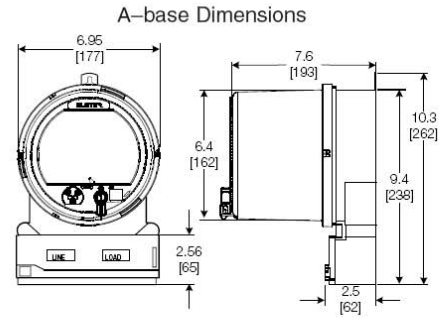

Dimensions in inches [millimeters]. For reference only. Do not use in construction.

ALPHA Plus Meter Specifications and Technical Data

Absolute Maximums

Voltage	Continuous at maximum of operating range	
Surge voltage withstand	Test performed	Results
	ANSI C37.90.1 Oscillatory	2.5 kV, 2500 strikes
	Fast Transient	5 kV, 2500 strikes
	ANSI C62.41	6 kV @ 1.2/50 μ s, 10 strikes
	IEC 61000-4-4	4 kV, 2.5 kHz repetitive burst for 1 minute
	ANSI C12.1 Insulation	2.5 kV, 60 Hz for 1 minute
Current	Continuous at Class Amperes	
	Temporary (1 second) at 200 % of meter maximum current	

Operating Ranges

Voltage	Nameplate nominal range	Operating range
	120 V to 480 V	96 V to 528 V
	63 V to 240 V	54 V to 264 V
	120 V to 240 V	96 V to 264 V
	240 V	192 V to 264 V
Current	0 to Class amperes	
Frequency	Nominal 50 Hz or 60 Hz \pm 5 %	
Temperature range	-40 °C to 85 °C inside meter cover	
Humidity range	0 % to 100 % noncondensing	

Operating Characteristics

Power supply burden (phase A)	Less than 3 W		
Per phase current burden	0.1 milliohms typical at 25 °C		
Per phase voltage burden	0.008 W @ 120 V	0.03 W @240 V	0.04 W @ 480 V
Accuracy	Power supply	ANSI C12.20 accuracy	
	120 V to 480 V	Meets accuracy Class 0.2 %	
	120 V to 240 V		
	Dedicated 240 V		
	63 V to 240 V	Meets accuracy Class 0.5 %	

General Performance Characteristics

Starting Current			
Form 1S and Form 3S	10 mA for Class 20	100 mA for Class 200	160 mA for Class 320
All other forms	5 mA for Class 20	50 mA for Class 200	80 mA for Class 320
Startup delay	Less than 3 seconds from power application to pulse accumulation		
Creep 0.000A (no current)	No more than one pulse measured per quantity, conforming to ANSI C12.1 requirements		
Primary time base	Power line frequency (50 Hz or 60 Hz), with selectable crystal oscillator		
Secondary time base	Meets the ANSI limit of 0.02 % using the 32.768 kHz crystal. Initial performance is expected to be equal to or better than \pm 55 seconds per month at room temperature		
Outage carryover capacity	6 hours at 25 °C. Supercapacitor rated at 0.1 Farads, 5.5 V		
Battery (optional)	LiSOCl ₂ battery rated 800 mAh, 3.6 V and shelf life of 20+ years. 5 years continuous duty at 25 °C		
Communications rate	Optical port	9600 bps (nominal)	Remote communications 1200 to 19,200 bps

Approximate Shipping Weights

	Single	4-pack
S-base	5.5 lbs (2.49 kg)	15.5 lbs (7.03 kg)
A-base	7.5 lbs (3.4 kg)	26 lbs (11.8 kg)



Byram Laboratories, Inc.

1 Columbia Road

Branchburg, NJ 08876

800-766-1212 * Fax: 908-252-0822

www.byramlabs.com